

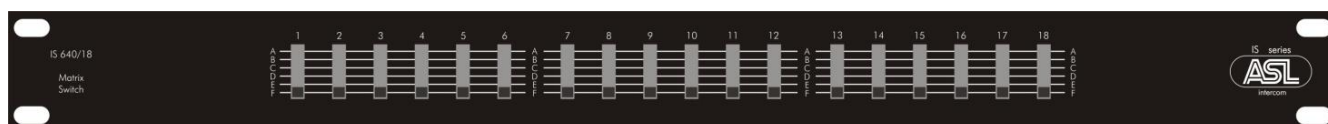

# IS 640-18 MATRIX SWITCH PANEL



## USER MANUAL

Issue 2011 © ASL Intercom BV

### DESIGNED AND MANUFACTURED BY:

ASL INTERCOM BV  
ZONNEBAAN 42  
3542 EG UTRECHT  
THE NETHERLANDS  
PHONE: +31 (0)30 2411901  
FAX: +31 (0)30 2667373  
E-MAIL: [info@asl-inter.com](mailto:info@asl-inter.com)  
WEB: [www.asl-inter.com](http://www.asl-inter.com)

## 1.0 GENERAL DESCRIPTION

To the IS 640-18 may be connected:

- A maximum of 6 intercom channels, coming from for instance a 6-channel power supply (PS 680) or a 6-channel speaker master station (PS 6379).
- A maximum of 18 intercom lines. To each intercom line one or several user stations may be connected.

Each intercom line may be assigned to one of the 6 intercom channels, using 6-position slide switches.

The cabling of intercom lines and intercom channels is standard microphone cable.

The IS 640-18 is a 19" unit, taking 1U of rack space.

## 2.0 FRONT PANEL

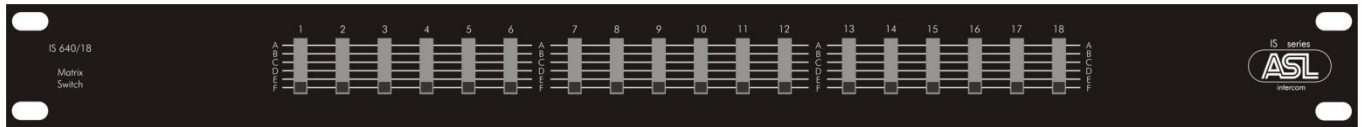

Each slide switch assigns the audio wire of each intercom line (labeled 1 – 18) to the audio wire of one of the 6 intercom channels (labeled A – F).

## 3.0 REAR PANEL

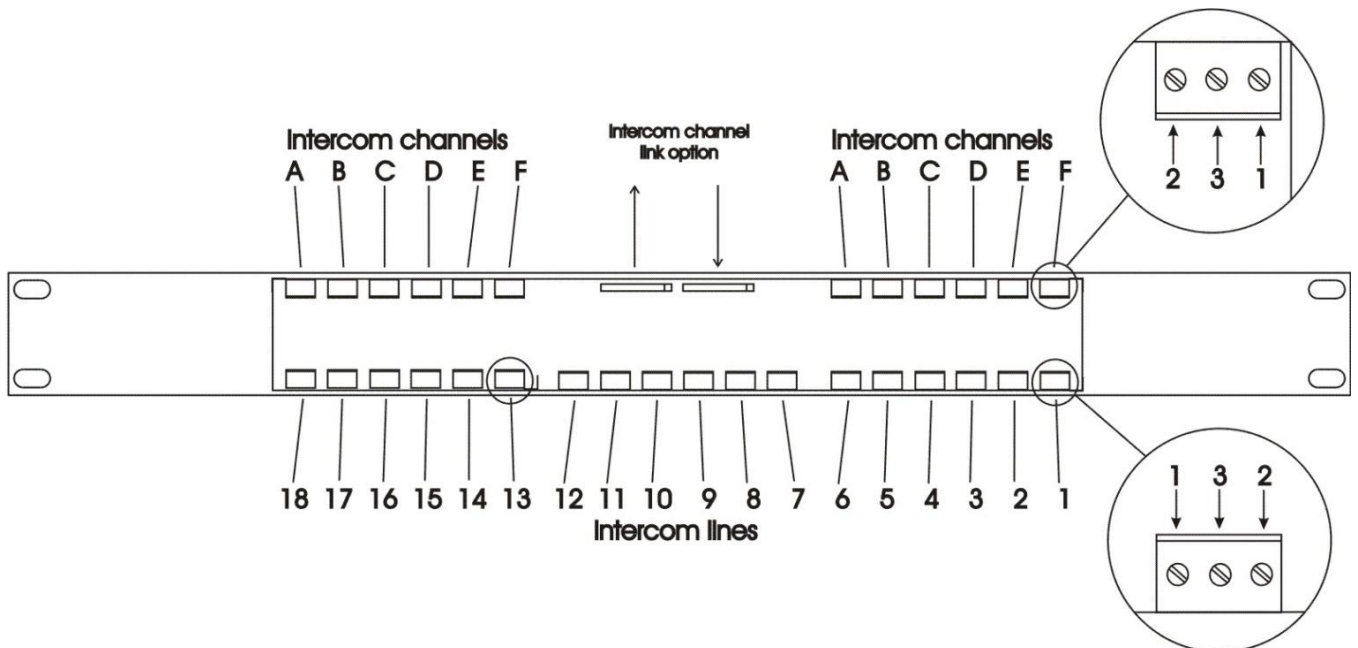

The intercom channels and the intercom lines are connected to the rear panel.

The connection points are small terminal strips (see detail in drawing) which are labeled A - F for the intercom channels and 1 – 18 for the intercom lines. To each terminal strip the two conductors and the shield of each microphone cable can be connected.

The 6 intercom channels can be extended to a next IS 640-18 or IS 640-12 unit.

The “through” intercom channels have to be connected to the second set of connection points A – F.

Another way of extending the intercom channels is to use the ‘intercom channel link option’ (see drawing). It concerns 2 sets of connection points, shaped for flat cables (1/10” pitch), allowing to link the intercom channels to one or several IS 640-18 units. This in case these units are mounted above each other. See drawing on next page.

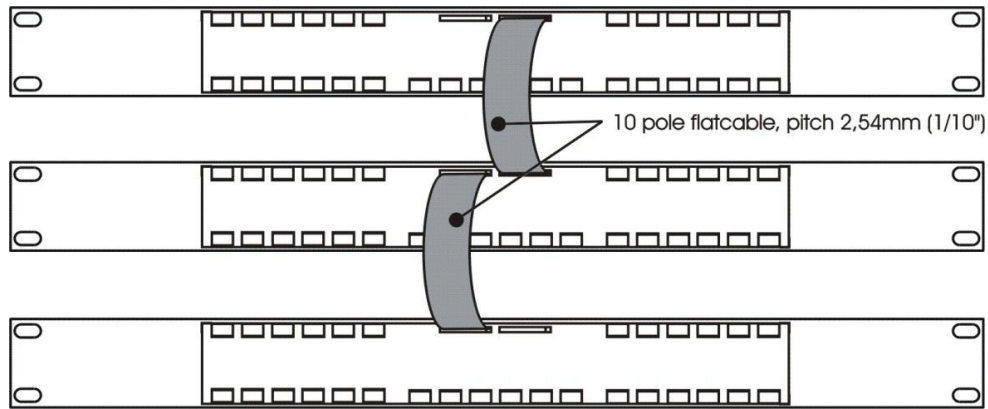

#### 4.0 INTERNAL WIRING IS 640-18

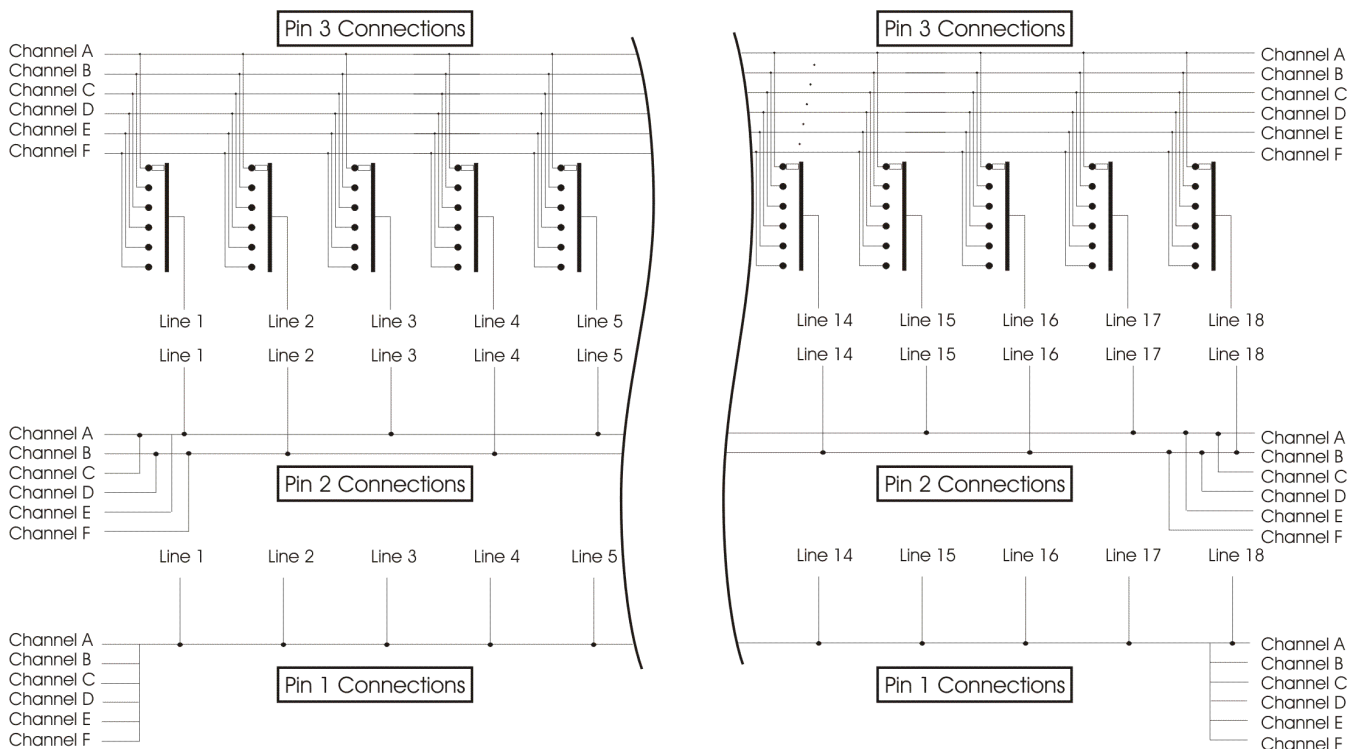

##### *Pin 3 connections:*

Each slide switch assigns the audio wire of each intercom line (labeled 1 – 18) to the audio wire of one of the 6 intercom channels (labeled A – F).

##### *Pin 1 connections:*

The 0V/ground wire of all intercom channels are connected to the ones of all intercom lines.

##### *Pin 2 connections:*

The 30V DC line power for the intercom lines with odd numbers is derived from the line power on channel A, C and E.

The 30V DC line power for intercom lines with even numbers is derived from the line power on channel B, D and F.

#### 5.0 DIMENSIONS & WEIGHT

Width: 19" / 483 mm  
Height: 1,75" / 44,5 mm

Depth: 25 mm  
Weight: 320 grams